

PCA304824-00000

PCX POLYMER CONCRETE ASSEMBLY

30" x 48" x 24"
(For actual dimensions see drawing)

Polymer Concrete Assembly, Straight Sides, No Floor, WUC 3.6, ANSI/SCTE 77 - "T15/20K," 3/8" Hex Bolts, Standard Nameplate (Specify at time of order) Shipped Separately

LOAD RATINGS

Incidental Traffic - Parking Lot, Sidewalk
Conforms to:

- WUC 3.6
- ASTM C 857
- ANSI/SCTE 77

FEATURES:

- Drop-In nameplate
- Shipped assembled
- Skid resistant cover
- Stainless steel bolts
- Cast-in floating nut box
- Integral drain holes

Additional product information
continued on the reverse

PCXTM
POLYMER CONCRETE
The Next Generation

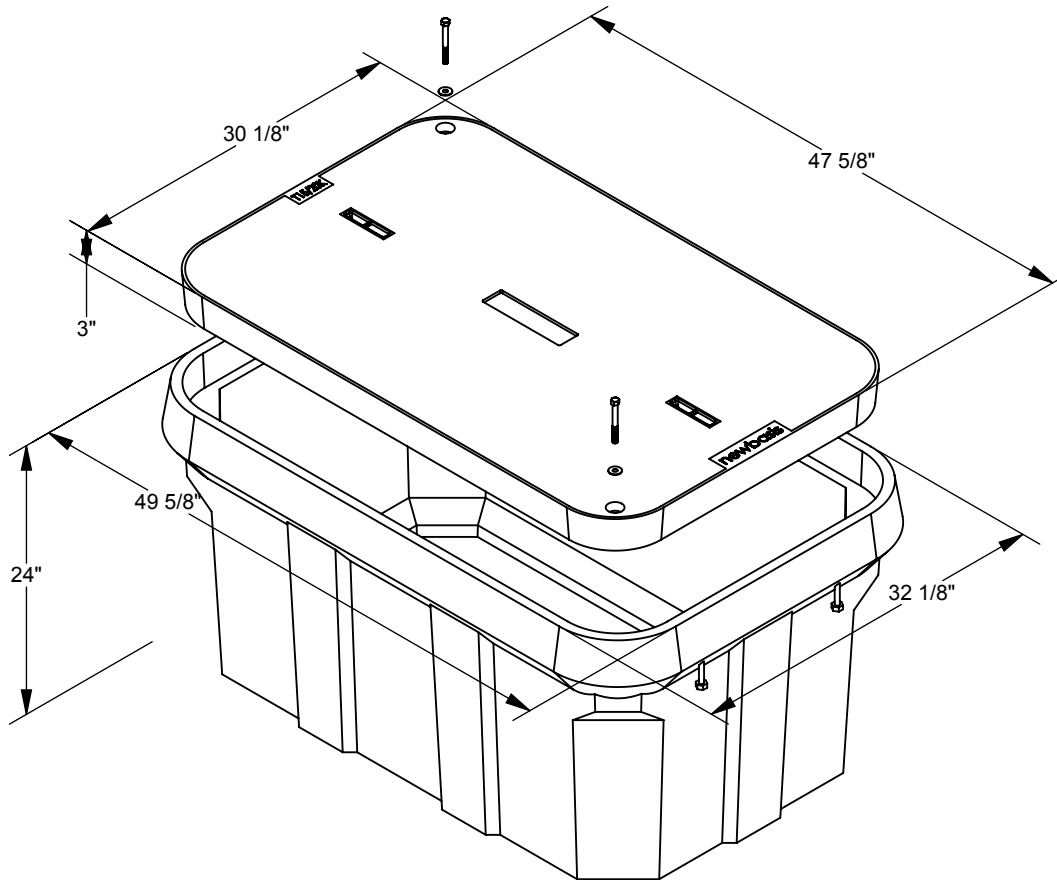

newbasis
Composites for Infrastructure

2626 Kansas Avenue
Riverside, California 92507

951.787.0600

951.787.0632 (fax)

info@newbasis.com

newbasis.com

Inside Dimensions

Length	Width	Depth
45 13/16"	28 3/16"	21"
41 1/16"	23 1/16"	

Rev: C.1

PCA304824-00000

PCX POLYMER CONCRETE ASSEMBLY



Polymer Concrete Assembly, Straight Sides, No Floor, WUC 3.6, ANSI/SCTE 77 - "T15/20K," 3/8" Hex Bolts, Standard Nameplate (Specify at time of order) Shipped Separately

30" x 48" x 24" For actual dimensions, see drawing on front side.

AVAILABLE OPTIONS

- Tier 22 Load Rating
- Penta Bolts
- Telephone EMS
- Power EMS
- 2 Piece Cover
- Custom Nameplate Installed
- Custom Nameplate Shipped Separately
- Standard Nameplate Installed
- Standard Nameplate Shipped Separately

- Indicates a selected option

NAMEPLATES

One standard nameplate included with each assembly, installed at the factory or easily installed in the field. Custom nameplates are available. Contact customer service.

Standard Nameplates

- Electric
- Telephone
- Fiber Optic
- Street Lighting
- Traffic
- CATV
- Communications

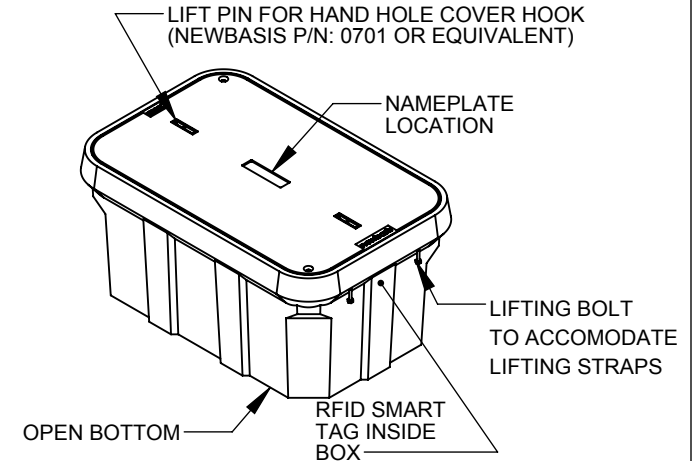

MATERIAL PROPERTIES AND ATTRIBUTES

Compressive Strength
Polymer Concrete - 11500 PSI
Per ASTM D695

Flexural Strength
Polymer Concrete - 4000 PSI
Per ASTM D790

Coefficient of Friction (Dry)
1.085
Per ASTM C1028

- Polymer Concrete
- Advanced composite: Very high strength to weight ratio
 - Non-metallic
 - Non-conductive
 - UV Resistant
 - High impact resistant
 - Impervious to chemicals and moisture

Materials tested in accordance with ASTM D-543 and ASTM D-570

WEIGHTS AND SHIPPING

COVER WEIGHT: 218.95 lbs.

BOX WEIGHT: 350.5 lbs.

ASSEMBLY WEIGHT: 569.45 lbs.

LOADED PALLET WEIGHT: 1,734.35 lbs.

Standard shipping includes van delivery of pallet quantities to the lower 48 states. Partial pallet quantities and flat bed shipping available at an additional cost.

PACKAGING (Steel Banding, Edge Protection)

PALLET QUANTITY: 3

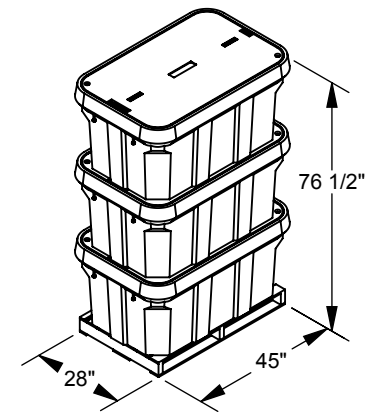

Rev: C.1